

10" - 200W Neodymium Guitar Loudspeaker

N 10/100 TR - 8 Ω

Code ZJ05360

GENERAL CHARACTERISTICS

| | | |
|-----------------------------------|------|----|
| Nominal Overall Diameter | 259 | mm |
| Nominal Voice Coil Diameter | 50 | mm |
| Magnet Weight | 200 | g |
| Flux Density..... | 1.20 | T |
| Weight..... | 1.75 | Kg |

THIELE-SMALL PARAMETERS

| | | | |
|------------------------------------|--------------|--------|-----------------|
| Voice Coil DC Resistance | R_E | 6.33 | Ω |
| Resonance Frequency | f_s | 108.2 | Hz |
| Mechanical Q Factor..... | Q_{MS} | 13.35 | |
| Electrical Q Factor..... | Q_{ES} | 0.58 | |
| Total Q Factor | Q_{TS} | 0.55 | |
| Mechanical Moving Mass | M_{MS} | 18.9 | g |
| Mechanical Compliance | C_{MS} | 115 | μm/N |
| Force Factor | $B \times l$ | 11.86 | Wb/m |
| Equivalent Acoustic Volume..... | V_{AS} | 17.7 | lt. |
| Maximum Linear Displacement | X_{MAX} | +/-1.0 | mm |
| Reference Efficiency | η_0 | 3.73 | % |
| Diaphragm Area | S_D | 330.1 | cm ² |
| Losses Electrical Resistance..... | R_{ES} | 146.5 | Ω |
| Voice Coil Inductance @ 1kHz | L_E | 0.7 | mH |

CONSTRUCTIVE CHARACTERISTICS

| | |
|-------------------------|---------------------|
| Magnet..... | Neodymium |
| Voice Coil Winding..... | Aluminium |
| Voice Coil Former..... | Kapton |
| Cone | Paper |
| Surround..... | Paper - Integrated |
| Dust Dome | Non Treated Cloth |
| Basket | Pressed Sheet Steel |

ELECTRICAL CHARACTERISTICS

| | | |
|------------------------------|------|----|
| Nominal Impedance..... | 8 | Ω |
| Musical Power | 200 | W |
| Rated Power* | 100 | W |
| Sensitivity @ 1 W, 1 m | 98.9 | dB |

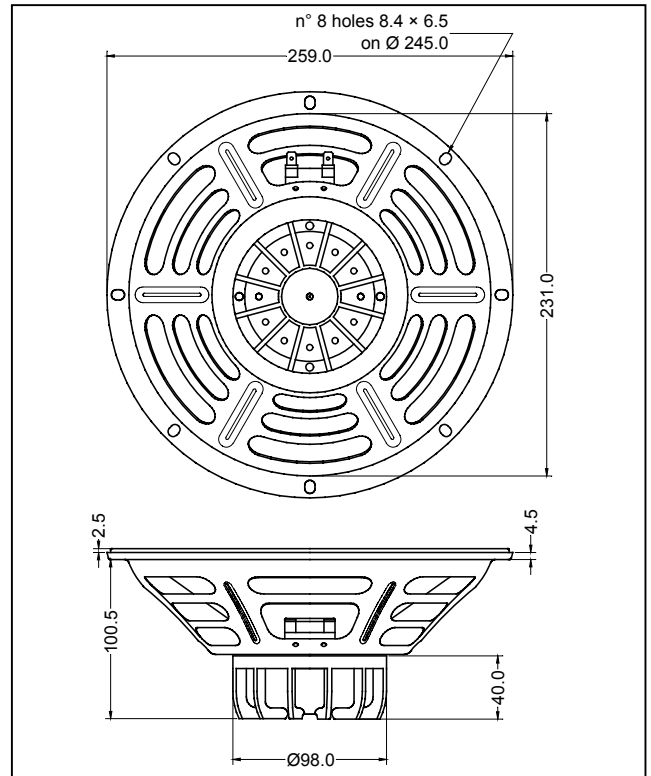

*rated power measured with 2 hours test with pink noise signal, 6 dB crest factor, loudspeaker mounted on enclosure
Thiele-Small parameters measured with I ASFR system

Frequency Response on IEC Baffle (DIN 45575) @ 1 W, 1 m - Impedance

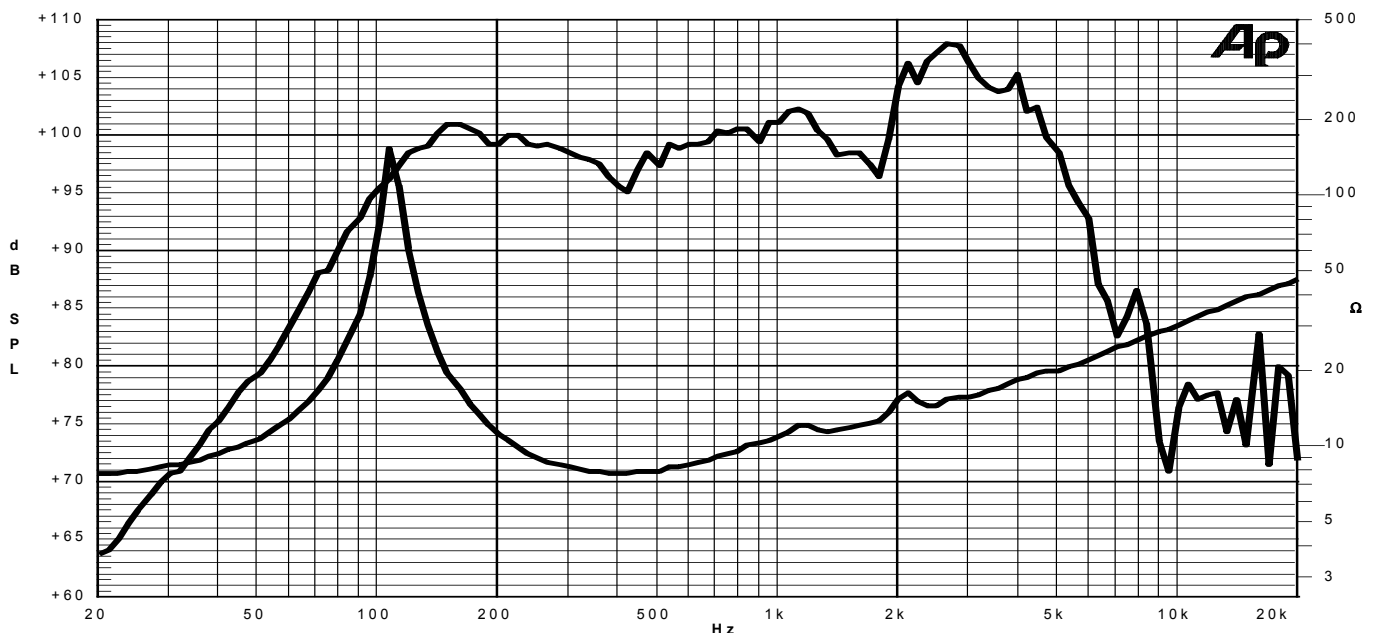

Due to continuing product improvement, the features and the design are subject to change without notice.

03/03/09